

Bearing Current Protector (BCP)

Introduction. Advances in semiconductors and power electronics technologies have made adjustable - speed drives (ASDs) with pulse width modulation (PWM) technology a popular choice for many motor-driven processes. Originally, ASD with PWM inverters had switching rates between 1 and 8 kHz. To eliminate the audible motor noise caused by such low switching frequencies, manufacturers developed ASDs with switching frequencies as high as 20 kHz. The faster switching frequencies did reduce motor noise, but they also created a side effect excessive motor-shaft voltage and current that can discharge across the motor bearings.

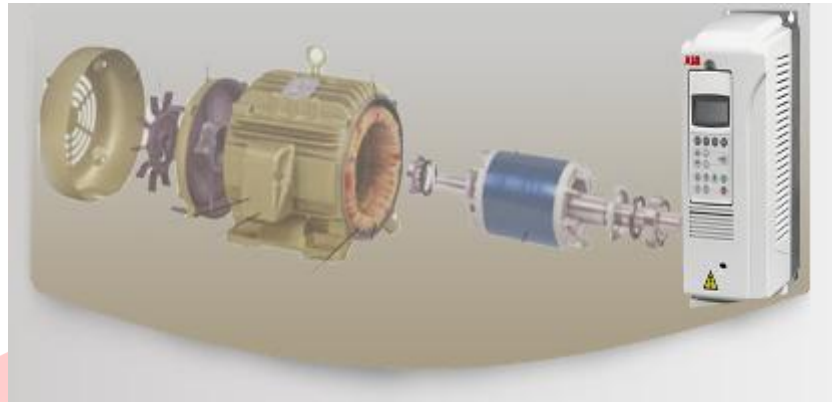

ASDs that use insulated-gate bi-polar transistors (IGBTs) as high-frequency switches are most likely to cause bearing discharge current. The high switching frequency and fast rise times of an IGBT inverter output can cause induced voltage in the rotor to be capacitive coupled to Motor shaft. As shown in Figure 1, this shaft voltage can exceed the dielectric strength of Lubricant in shaft bearings. The resulting current Flows from the shaft, through the bearing Lubricant, and to the, and to the grounded motor frame, pitting or fluting the bearing races. The resulting high rolling resistance leads to premature failure of the shaft bearings. This Application Provides ASD user with some pragmatic insights into the nature of the problem caused by Bearing discharge currents and suggests preventive or corrective actions to avoid the problem.

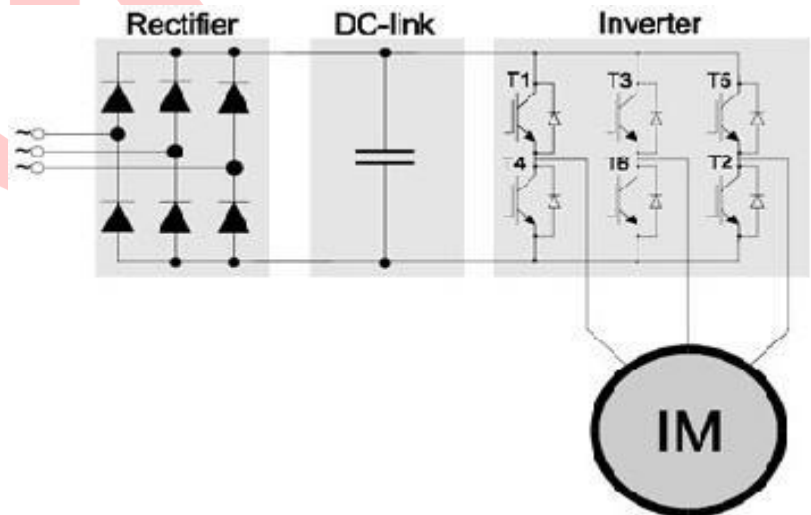

Audible motor noise and vibration are usually the first obvious symptoms of premature bearing failure. Because excessive noise and vibration can be symptoms of other motor problems, Maintenance personnel frequently

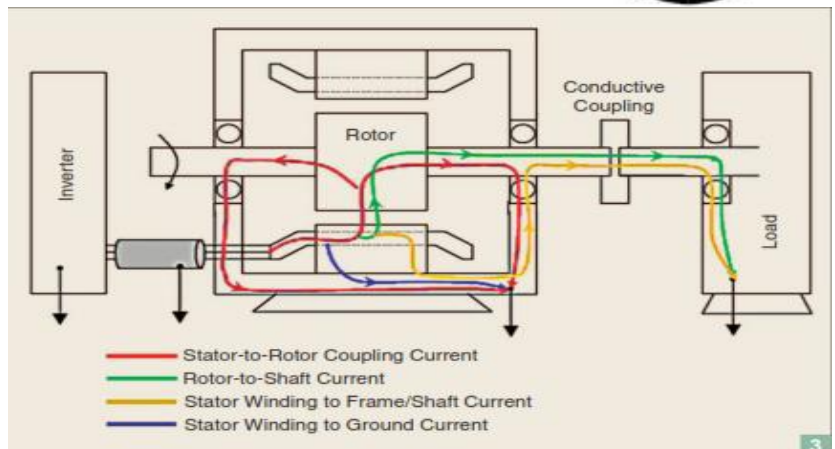

Radiant Corporation



misdiagnose problems caused by fluting. Usually, the current Arcing across the bearings will first damage the smaller idle bearing opposite the end of the shaft connected to the motor load. Idle-bearing failure can occur as soon as six months after the motor has been installed. Discharge current may also damage the bearings of other equipment connected to the motor shaft, such as direct connected tachometers and gear boxes. In many cases, discharge current will damage the tachometer bearings instead of the motor bearings because the smaller tachometer bearings offer the path of least resistance. Damaged tachometer bearings can cause the tachometer to vibrate, resulting in an erratic signal from the tachometer.

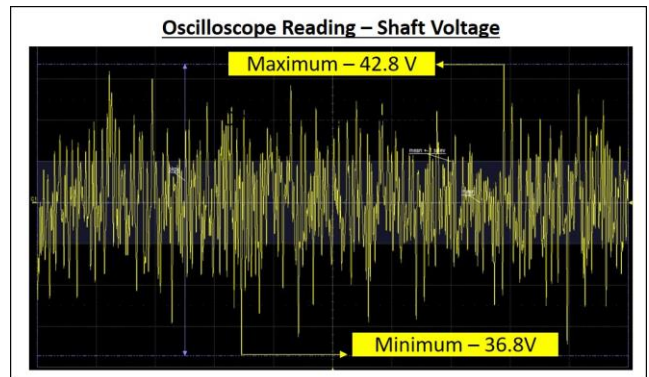

A shaft voltage as low as six volts can cause arcing through the bearing lubricant, depending upon the type of bearing lubricant and the clearing between the race and the ball bearings.

Excessive shaft voltage can be verified in two ways. One way is to measure the shaft-to-ground voltage, which requires a specialized shaft-monitoring device. If motor bearings have already failed, then inspect the bearing races for fluting and the ASD driving the motor is a PWM-type with a switching frequency above 10 kHz, then most likely the shaft voltage is excessive.

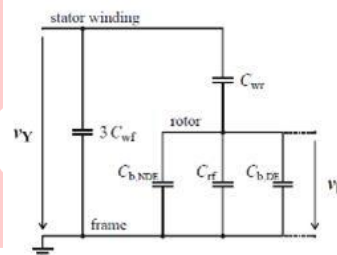

Figure : Equivalent circuit of the main capacitances of an induction or PM synchronous machine that are important at high frequencies

Bearing Voltage Ratio, short "BVR"

$$BVR = \frac{\text{bearing voltage}}{\text{stator winding common mode voltage}} = \frac{v_b}{v_Y} = \frac{C_{wr}}{C_{wr} + C_{rf} + 2C_b}$$

Circulating Current.

The high dv/dt at the motor terminals causes - mainly because of the stator winding to- frame capacitance Cwf - an additional ground current ig. The frequencies of these currents range from f(ig) _ 100 kHz up to f(ig) = several MHz. The ground current ig excites a circular magnetic flux around the motor shaft. This flux induces a shaft voltage Vsh along the shaft of the motor. If Vsh is large enough to puncture the lubricating _lm of the bearing and destroy its insulating properties, it causes a circulating bearing current ib along the loop \stator frame - non drive end - shaft - drive end". Because this type of bearing current is due to inductive coupling, it mirrors the ground current. It is of deferential mode, the bearing currents being of opposite direction in both bearings. To prevent from circulating current the motor is/should be provided with NDE (non-drive end) Insulated bearing.

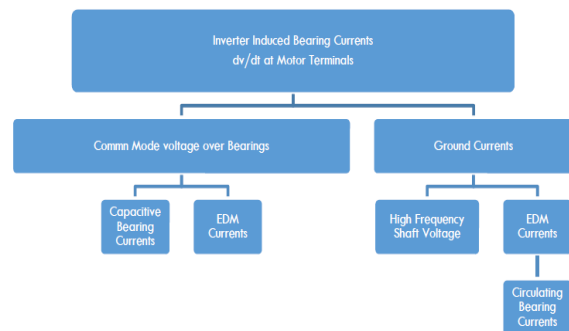

Grease Ingress Protection. We provide grease ingress protection models also.

Radiant Corporation



Electrostatic discharge currents. At intact lubrication I_m , the bearing voltage V_b mirrors the common mode voltage at the stator terminals V_Y (bearing temperature, motor speed $n \approx 100$ /min) via the capacitive voltage divider BVR (Bearing Voltage Ratio), as it was described before (Section 1.4). Hence, the bearing voltage V_b is determined via the BVR by the common mode voltage of the stator windings $V_b = V_Y * BVR = (V_Y * C_{wr}) / (C_{wr} + C_{rf} + 2C_b)$

Applications.

- ✓ *Electrical Generators*
- ✓ *Propulsion Gearboxes*
- ✓ *Propeller Angle Control Motors*
- ✓ *Bow Thrusters*
- ✓ *Rudder Control Motors*
- ✓ *Fuel Pumps*
- ✓ *HVAC Chillers*
- ✓ *Refrigeration Compressors*
- ✓ *Desalinization Pumps*
- ✓ *Potable Water Pumps*
- ✓ *Black Water Tank Pumps*
- ✓ *Ballast Water Treatment Pumps*
- ✓ *Bilge Pumps*
- ✓ *Onboard Cranes and Winches*
- ✓ *Materials Handling Pumps and Conveyors*
- ✓ *Hold Hatch Motors*
- ✓ *Anchor Winch Motors etc. Applicable for all motors using bearings*

!!! Radiant Corporation - is a manufacturer of Bearing Control Protector unit.

"We create tailor made units based on your and motor requirements We customize as per your requirements & dimensions. If you have any requirements"

..... We are a Click/ Call Away!!!

!! Don't forget to spread the message to your family, friends & colleagues too !!

For more details and other products range kindly visit our website www.radcorps.com